

9 PC DINING SET TABLE IT-620164

ASSEMBLY INSTRUCTIONS

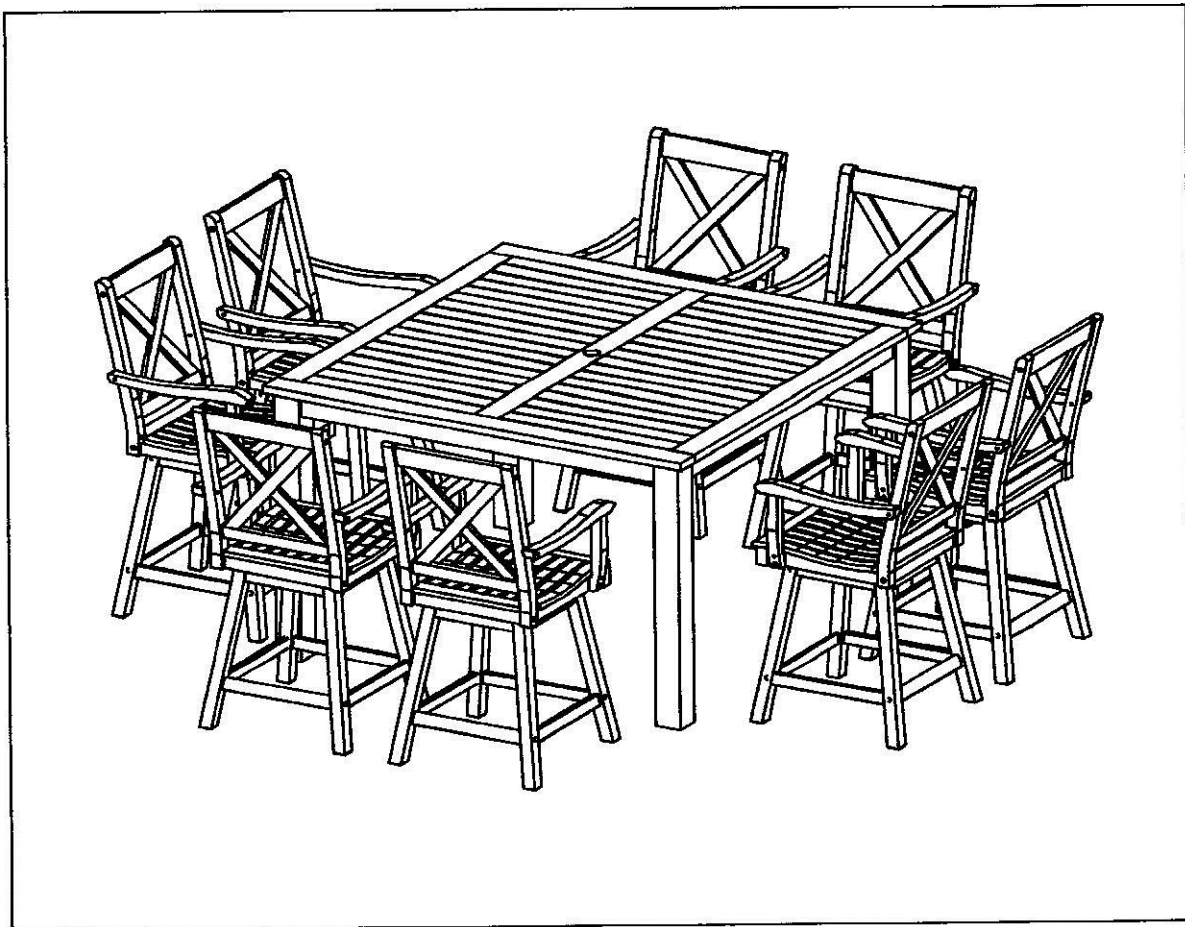

QUESTION ?

Identify all parts and hardware. If any pieces are missing call our toll free number at 1-888-287-4275 from 9:00 am to 5:00 pm CST (Monday to Friday) for replacement parts. For faster service, have the style number handy when calling.

ASSEMBLY INSTRUCTIONS

IMPORTANT !



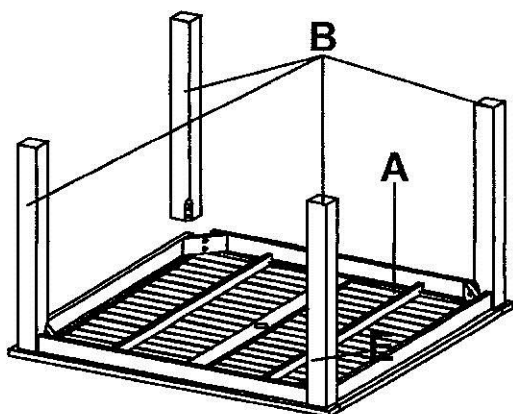

- * ASSEMBLE YOUR UNIT IN AN AREA FREE FROM ANY OBJECTS THAT MIGHT SCRATCH THE SURFACE OF YOUR UNIT.
- * EXAMINE ALL PACKING MATERIAL BEFORE DISCARDING, SHORTAGES MAY OCCUR FROM PARTS LEFT IN THE PACKING MATERIAL.
- * PLEASE READ THE INSTRUCTIONS CAREFULLY, AND VERIFY ALL PARTS ARE INCLUDED.
- * ALL NUTS NEED TO BE TIGHTENED FROM TIME TO TIME TO AVOID DAMAGE.



LIST OF WOODEN PARTS

NO.	DESCRIPTION	Q'TY
A	Top table	1 Pc
B	Leg	4 Pcs

LIST OF HARDWARE PARTS

- | | | |
|---|---|--------------------------------|
| C |  | Washer 8 Pcs + 1 |
| D |  | Spring washer 8 Pcs + 1 |
| E |  | Nut 8 Pcs + 1 |
| F |  | Umbrella hole plug 1 set |

TOOLS REQUIRED

For proper assembly use these tools (included)

- Wrench
- for tightening nuts.



STEP 1

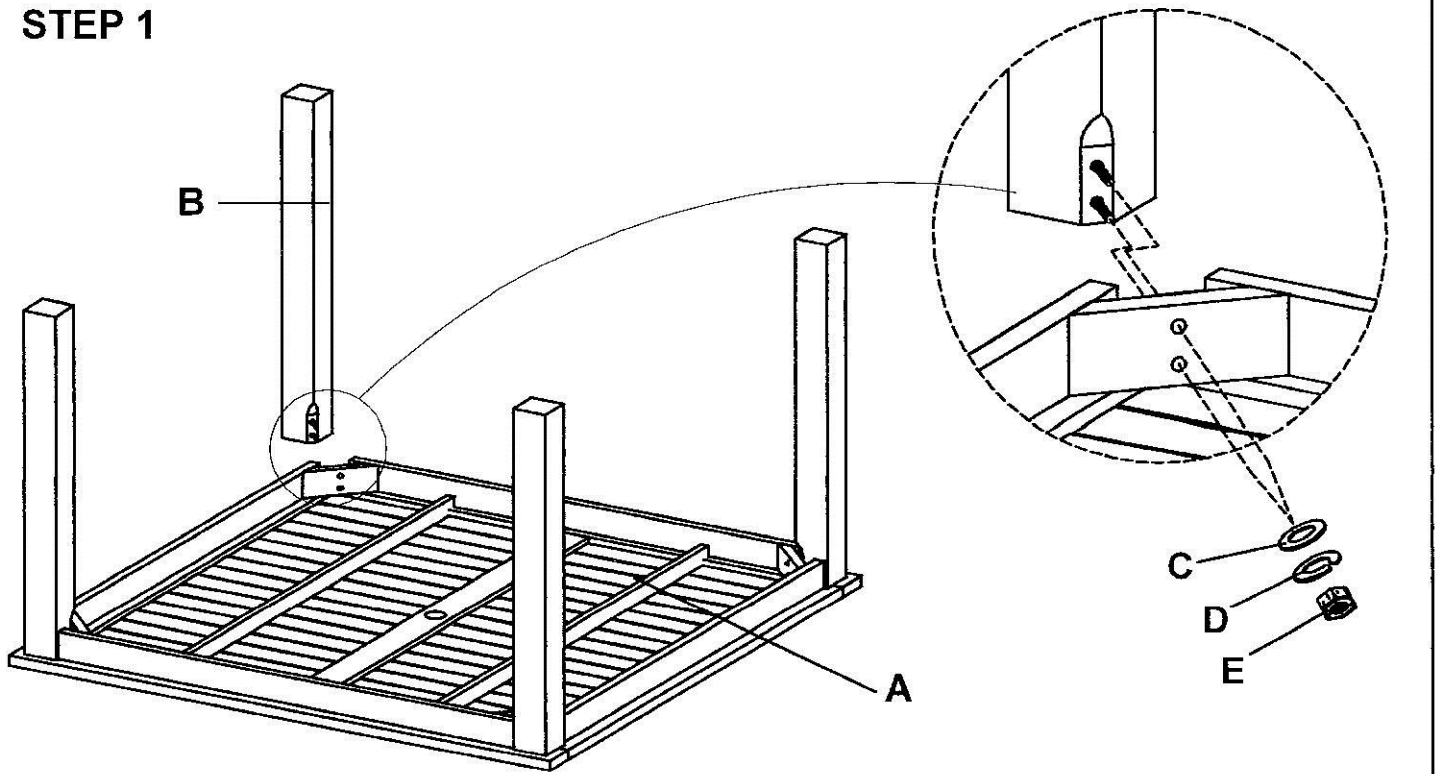

- Put the table (A) face down on a flat non abrasive surface.
- Attach the legs (B) into table top (A) and secure using metal washers (C), spring washers (D) and nuts (E) as diagram shown. Tighten all nuts completely using wrench.
- Turn the table upright.

STEP 2

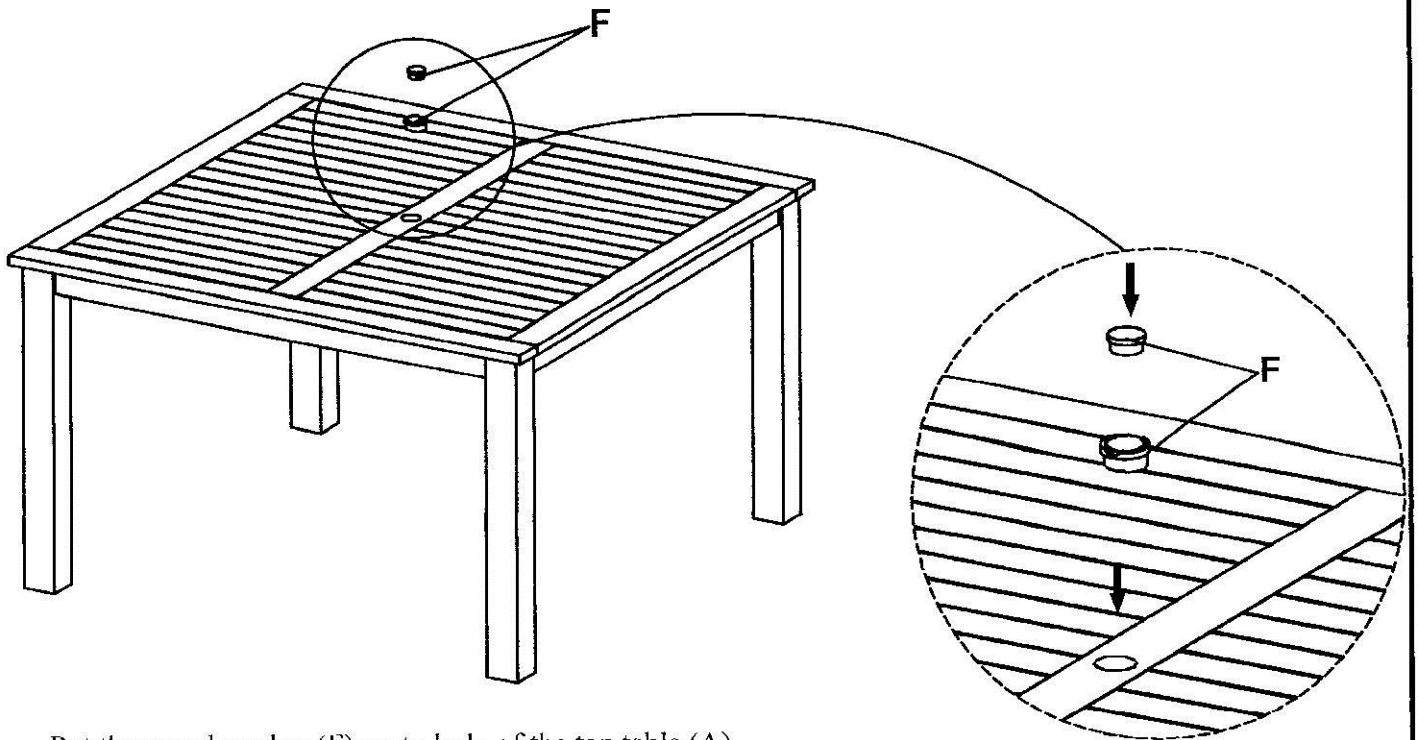

Put the wooden plug (F) on to hole of the top table (A).

THE TABLE IS NOW READY FOR USE.

9 PC HIGH DINING SET BAR CHAIR IT-620164

ASSEMBLY INSTRUCTIONS

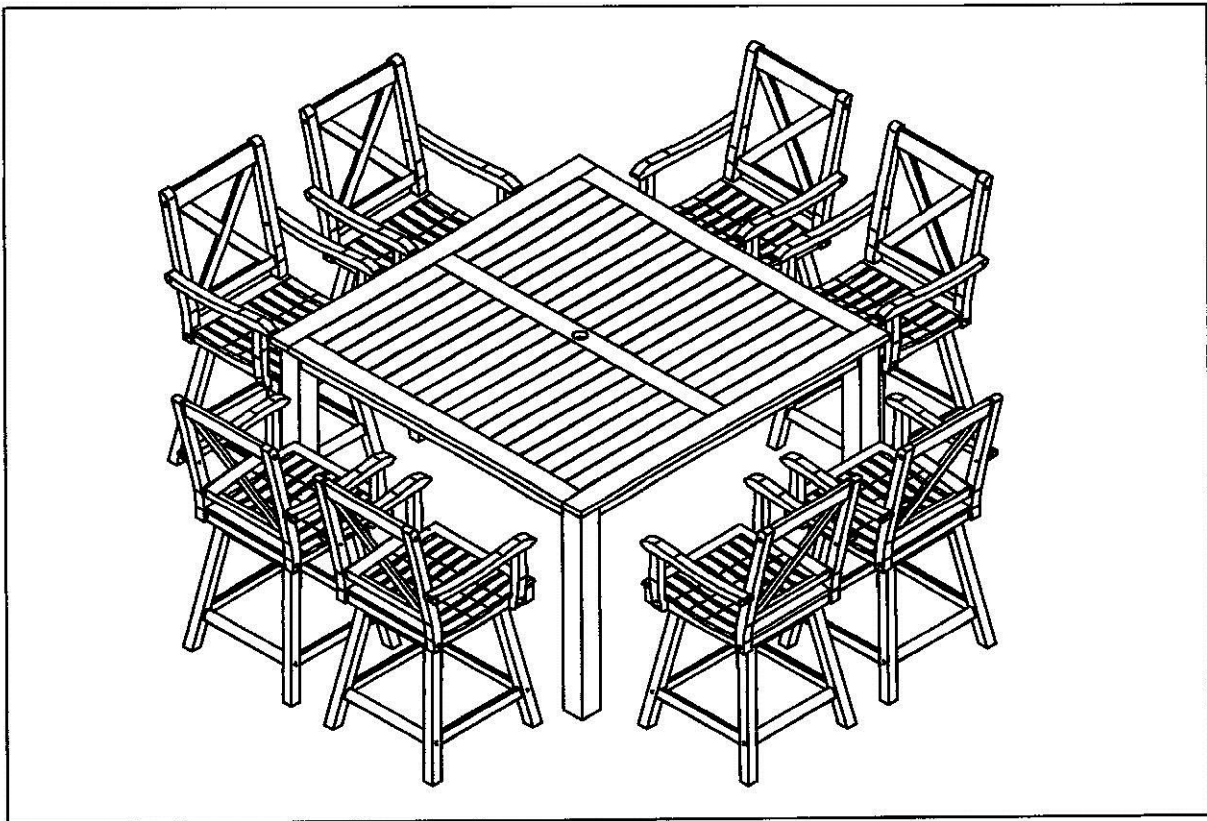

QUESTION ?

Identify all parts and hardware. If any pieces are missing call our toll free number at 1-888-287-4275 from 9:00 am to 5:00 pm CST (Monday to Friday) for replacement parts. For faster service, have the style number handy when calling.

ASSEMBLY INSTRUCTIONS

IMPORTANT !

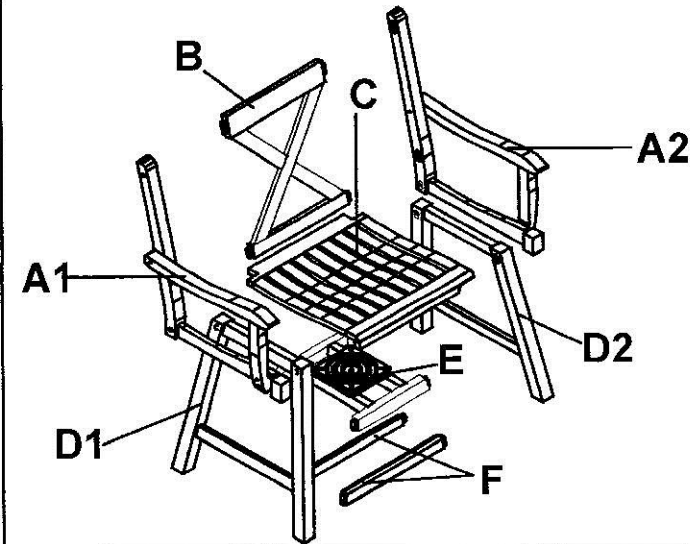

- * ASSEMBLE YOUR UNIT IN AN AREA FREE FROM ANY OBJECTS THAT MIGHT SCRATCH THE SURFACE OF YOUR UNIT.
- * EXAMINE ALL PACKING MATERIAL BEFORE DISCARDING, SHORTAGES MAY OCCUR FROM PARTS LEFT IN THE PACKING MATERIAL.
- * PLEASE READ THE INSTRUCTIONS CAREFULLY, AND VERIFY ALL PARTS ARE INCLUDED.
- * ALL BOLTS NEED TO BE TIGHTENED FROM TIME TO TIME TO AVOID DAMAGE.



LIST OF WOODEN PARTS

NO.	DESCRIPTION	Q'TY
A1	Right side frame	1 Pc
A2	Left side frame	1 Pc
B	Back support	1 Pc
C	Seat	1 Pc
D1	Right leg frame	1 Pc
D2	Left leg frame	1 Pc
E	Support w/swivel	1 Pc
F	Base support	2 Pcs

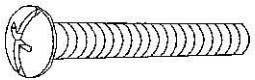
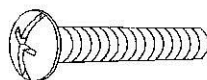
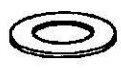
LIST OF HARDWARE PARTS

- G**  1 1/2" Bolt 14 Pcs + 1
- H**  1" Bolt 4 Pcs + 1
- I**  Washer 4 Pcs + 1
- J**  Wooden cap 14 Pcs + 1

TOOLS REQUIRED

For proper assembly use these tools (not included)

1. Phillips screwdriver
- for tightening all bolts and screws.
2. Rubber mallet
- for tapping in the wooden caps.



STEP 1

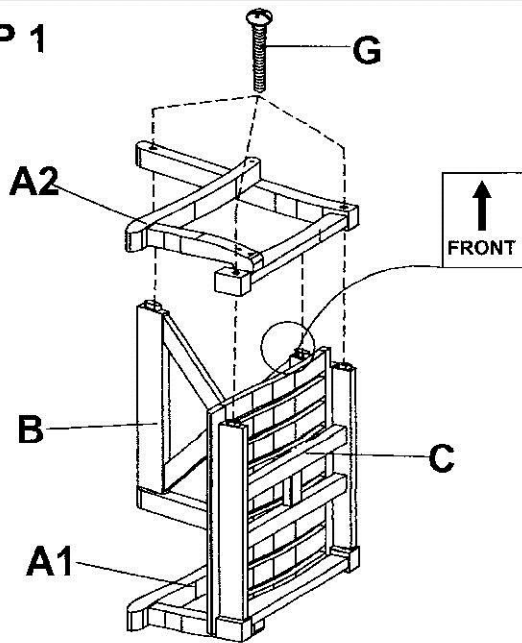

- Attach back support (B) and seat (C) to right side frame (A1) and then attach left side frame (A2) onto pre-assembly.
- Insert 1 1/2" bolts (G) to left side frame (A2), position as shown.
- Do not fully tighten all bolts yet.

STEP 2

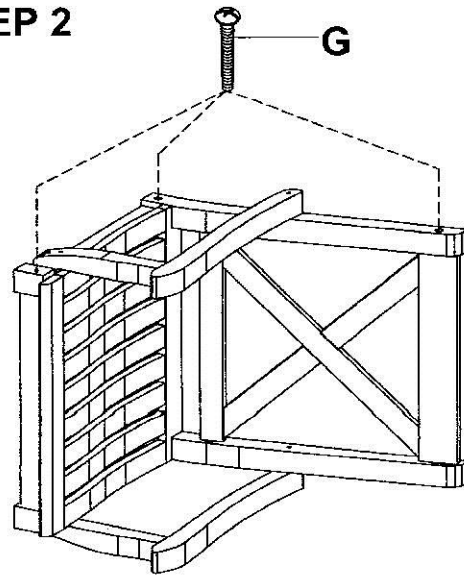

- Invert the chair and repeat the step 2 procedure to secure the frame.

STEP 3

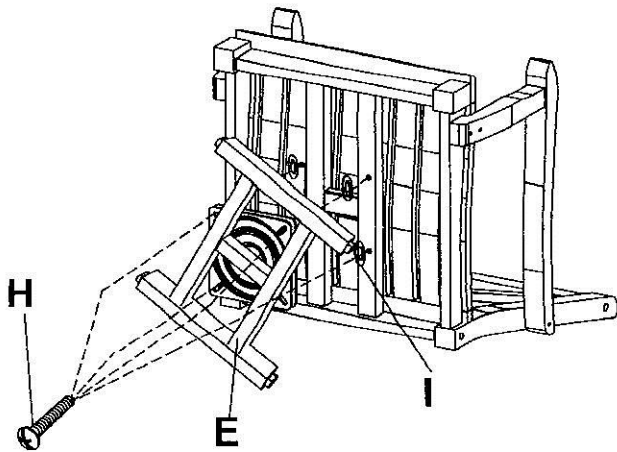

- Attach the washers (I) and the support w/swivel (E) to the assembly from step 2 and then insert 1" bolts (H) to swivel (E), position as shown.
- Tighten the bolts using screwdriver.

STEP 4

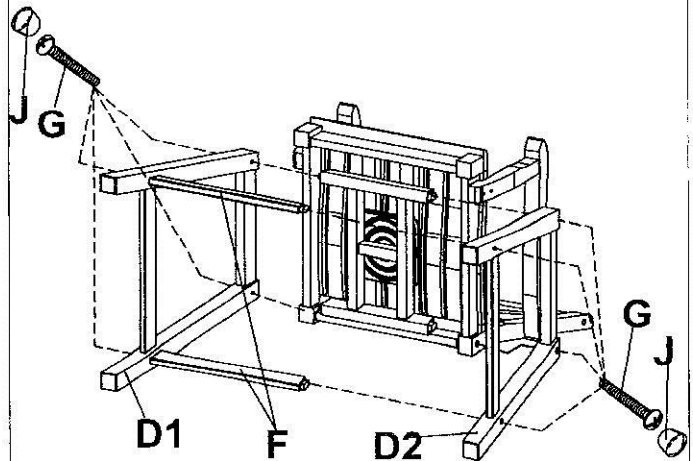

- Attach the base supports (F) to the right leg frame (D1), secure using 1 1/2" bolts (G).
- Next, attach leg frames (D) to the assembly from step 3, secure using 1 1/2" bolts (G).
- Make sure all parts are correctly connected and tighten all bolts completely using screwdriver.
- Tapping in the wooden caps (J) to cover bolts head using rubber mallet.

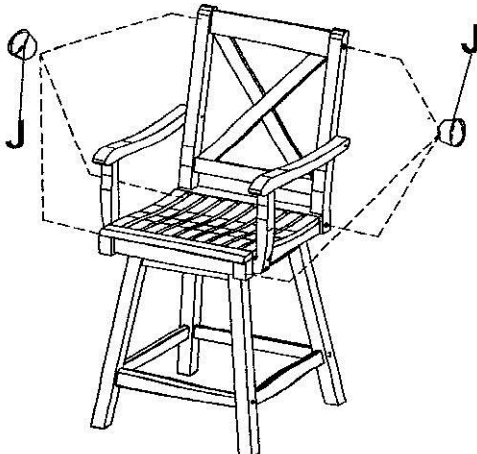

- Make sure all parts are correctly connected and tighten all bolts completely using screwdriver.
- Tapping in the wooden caps (J) to cover bolts head using rubber mallet.

The chair is now ready for use.